

BeeWrap⁺

Advanced mobile pallet wrapper



MOBILE WRAPPING ROBOT

100%
MADE in ITALY

BeeWrap+ is a mobile wrapping machine used for palletizing goods with stretch film. It is particularly **suitable for heavy weight items, unusual shapes, and loads with large dimensions**, ensuring the highest pallet security. It is equipped with a digital control panel that allows the user, in an easy and functional way, to alter various parameters and set-up customized wrapping cycle programs. The Beewrap+ is also equipped with the new AGM dry battery technology, providing higher performance and is maintenance-free.

This guarantees a higher working autonomy (up to 400 cycles per charge) and enhances safety within the machine!

Beewrap+ **is an excellent logistics solution** because **it is easy to move** and versatile for pallets of different shapes and sizes.

FEATURES & BENEFITS

- » Safety First – thanks to the new AGM dry battery technology there is no danger related to battery maintenance and acid leaks
- » Easier to transport – thanks to the AGM technology, batteries are not subject to any transport restrictions
- » Extensive safety – BeeWrap incorporates several safety features as standard (such as bumper, light and beeper indicator)
- » No film waste – with motorized Pre-Stretch system & independent tension control
- » Increased production capacity – thanks to customized settings
- » Versatile use – perfect for any type of load even the most complex wide and/or round ones
- » Flexibility – machine is easily moved to various locations
- » Modular system – meeting your individual needs
- » Easy-to-use – due to the simple control panel
- » CE compliant – engineered and produced in Italy according to Europeans safety standards
- » Customizable – film carriage with brakes (mechanical or electromagnetic) or powered prestretch (240%)

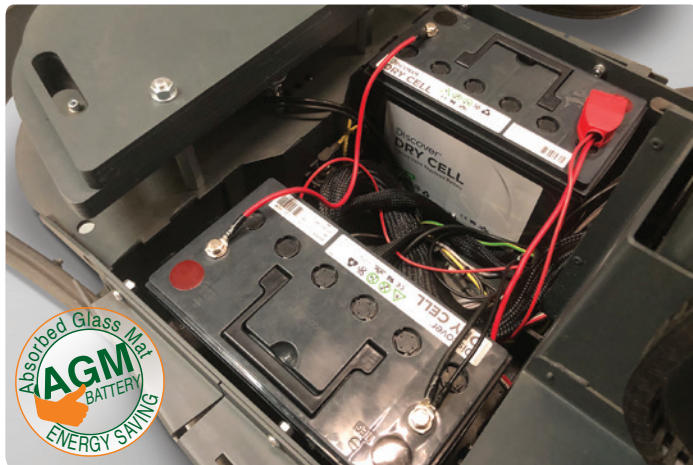

OPTIONS

- Photocell for black film or coloured products
- Remote control available with the 87 Ah battery option
- Film cutting system (on LP carriage only)
- Double tracing wheel
- Non-marking wheels
- Wheels for abrasive floor
- 87 Ah battery for 400 cycles* and energy saving (power off after 10 minutes)
- Automatic stop and restart function with a scanner
- Blue signal light to highlight maneuver area/where machine operates for added safety

Customize your **BeeWrap** with the most suitable carriage for your loads!



M - Mechanical brake



FM - Electromagnetic brake



LP - Powered pre-stretch 240%
(150%-200% - kit available as option)



Carriage for net/mesh

Operation indicator light and beeper for safer work condition.

Ergonomic, intuitive and easy to use control panel

New selector to restart the stand-by status

Emergency button

Flexibility: handle for manual moving

Adjustable height tracing wheel

Different column heights available

Different carriages available

Technical features

Nr. of pallets for single battery charge	250* with 58 Ah batteries and 400 with 87 Ah batteries
Rotation speed (m/min.)	50min. / 80max
Up & Down carriage speed (m/min.)	1min. / 5max
Power supply (V)	100Vac ÷ 240Vac
Installed power (kW)	0,35 Kw
AGM Batteries	2x 2V 58 Ah (C5) standard 2x 2V 87 Ah (C5) as optional

Min/Max loading sizes	Min.	Max
L (mm)	500	***
W (mm)	400	***
H (mm)	600	2100 2600
Weight (Kg)	45**	∞

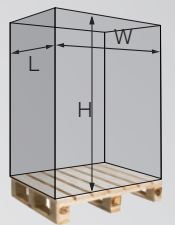
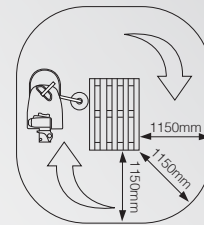

* Test conditions:
Standard Column 2100mm
AGM acid batteries
Pallet dimensions mm 800 x 1200 x 1500 (h),
up & down cycle, up & down cycle, and a total cycle time of 71 seconds.

** With film tension of 6daN applied.

*** Bulky load can be wrapped up to a total perimeter of 26 mt ln standard configuration.

Machine installed

H1	2410/2910 mm	2410/2910 mm
H2	65 mm	65 mm
W1	1255 mm	1255 mm
W2	733 mm	733 mm
L1	1482 mm	1547 mm
L2	1262 mm	1262 mm

Folded machine

 229(L)x98(w)x130(H)cm

	M/FM Carriages	LP Carriage
W	1027 mm	1029 mm
H	1094 mm	1147 mm
2100/2600 column		
L	2310/2810 mm	2310/2810 mm
Weight	316/355 kg	335/380 kg

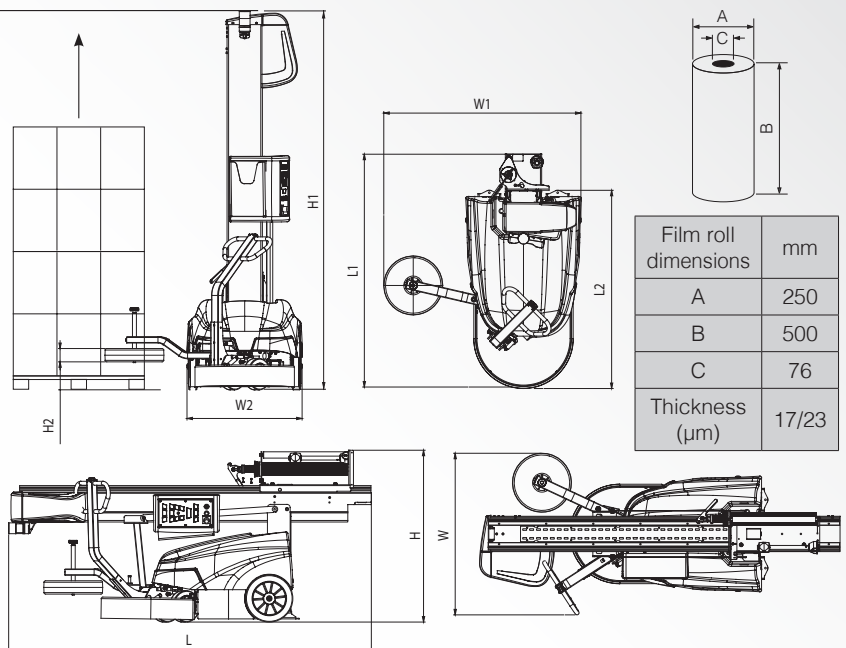



100%
MADE in ITALY

SIAT Group is the market leader in the production of machines for the packaging industry. It offers a wide range of machines for taping, wrapping, and strapping applications.

We produce more than 17.000 pieces of equipment per year and have manufacturing them for more than 50 years, proud to be recognized by our customers as the premium brand of machines for secondary packaging.

We offer products for many industries: food & beverage, e-commerce & logistics, packaging, and consumer products, resulting in a strong and durable offer for every need and every environment.

Our machines are designed to:

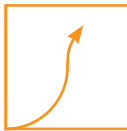

Increase customer productivity

Our machines boast an average life of 25 years, while our customers return from their investment in only 4 to 5 months.

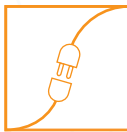

Lower the cost of ownership

Our machines require easy maintenance and simple installation. They are developed and designed to be user-friendly and for different applications of our customers, thanks to a research and development department that is always ready to respond to every need.



Reduce environmental impact

We strongly believe in pursuing this goal by following our vision: the future of packaging involves a strong collaboration with our customers to find the most suitable and safe solution. Each machine is designed to minimize consumable use, reduce waste and use less energy.



Be connected

Thanks to Optirun, SIAT Group's brand dedicated to IoT solutions, we can calculate consumption whether it is of tape, cardboard, film, strapping used, and monitor all machine parameters to avoid downtimes.



International Technical | **Packaging** | Applications

Via Puecher 22, 22078 Turate - Como

www.siat.com
www.shop.siat.com

Our pallet wrapping machines are designed and tested to handle the most common types of film. In addition, the use of SIAT film Viking carriages makes it possible to greatly reduce the film needed, by up to -75%, or about 45 meters of film and more than 400 grams per pallet wrapped.

