



markem·imaje

a **DOVER** company



Continuous inkjet

# 9750+: The true value of innovation



## The innovation you need. The experience you trust.

Markem-Imaje delivers even more flexibility and stability with our next-generation model, the 9750+.

Backed by decades of building dependable inkjet printers, the 9750+ breakthrough ink circuit—with its unique capacity to manage all types of inks, including contrast pigment inks for premium permanence and legibility—takes inventory streamlining and modularity to the next level. Meticulously engineered and qualified by the most modern methods, the 9750+'s latest enhancements bring you:

- Technology leaps grounded in time-tested industrial processes for maximized uptime, reduced maintenance
- Cutting-edge design with simplified UI and modular components for easy operation, maintenance or repair
- Clear, customizable and traceable black or colored codes that meet customers' growing demand for supply chain visibility and inventory streamlining

## Key benefits

### Enhanced ink circuit taking dye or pigmented inks

Advanced R&D backed by proven industrial processes and methods

- **Intelli'Inks** system ensures optimal coder performance and flexibility when coding different package materials—in all colors, with all inks
- **Intelli'Swap** technology streamlines mechanicals down to swappable modules
- **Jet Speed Control** technology automatically adjusts ink and printer variables to ensure drop placement, quality and code consistency. Every time.

### Sustainability

More sustainable solutions =  
Long-term value and lower TCO\*

- **Intelli'Swap** modularity enables you swap out only the individual parts that need to be replaced and not the entire block
- **Intelli'Design** process and a portfolio of rigorously developed ink formulations help reduce consumable consumption and VOC\* emissions by up to 50% while improving operator safety, well-being and TCO
- Consumable-saving mode additionally reduces consumption and waste

### Digitalization

Convenience only a couple clicks away

- Our Connected Printer Services powered by a secure IoT platform\*, allow for a predictive analysis and therefore help maximize uptime, achieve OEE\* objectives
- Consumable and spare part supply through online portal
- Quick customizable 24-pin interface allows for easy integration in a 4.0 connected environment

# 9750 continuous inkjet specifications

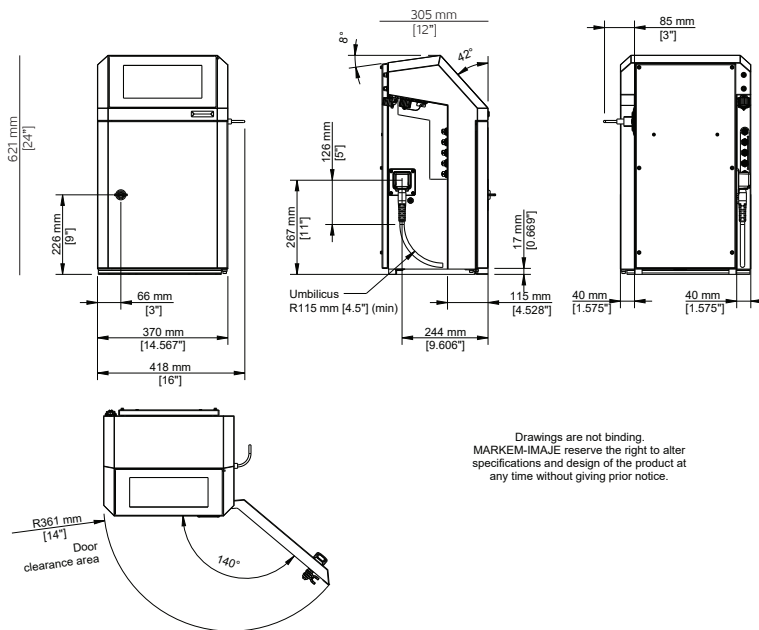

Drawings are not binding. MARKEM-IMAJE reserve the right to alter specifications and design of the product at any time without giving prior notice.

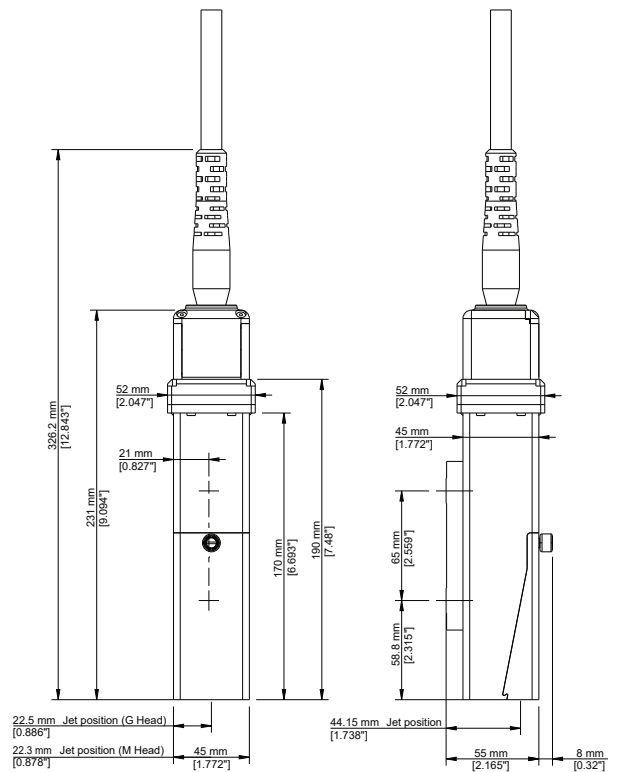

## Print features

Mono-jet printhead  
 G head (printing resolution: 71 dpi)  
 M head (printing resolution: 115 dpi)  
 Up to 5 lines of print  
 Print speed: up to 6.6 m/s  
 Font height from 5 to 32 dots  
 Character height: from 1.2 to 11.2 mm  
 Wide choice of 1D and 2D barcodes: EAN 8/EAN 13/UPCA /UPCE barcodes, code 39, interleaved 2 of 5, Datamatrix, QRcode, Dotcode, GS1 standard compliant  
 Wide choice of characters: Latin, Arabic, Cyrillic, Hebrew, Japanese, Chinese, Korean, etc.

## Other characteristics

Weight: 25 kg  
 Table-top or vertical mounting  
 Ultra-flexible 3-meter umbilical cable  
 Stainless steel cabinet and printhead case  
 Dust/water ingress protection rating: IP56 requiring no plant air  
 Operating temperature range: 32 °F to 122 °F (0 °C to 50 °C) depending on ink used  
 Humidity: 10 to 90% non-condensing  
 Electrical power supply: 100-240 V; 1,6 A; frequency 50/60 Hz; 30 W

## Operations

WYSIWYG 10-inch capacitive color touchscreen: real-time display of remaining print capacity expressed in hours and number of messages; integrated assistance and alert system; simplified message printing and management; creation of user profiles; tracking of consumption and printer availability  
 Message library (up to 1,000 messages)  
 Automatic selection of fonts, depending on print speed and printhead/object distance  
 Specific date management (rounding date function)  
 Parent/child connectivity  
 Jet Speed Control guarantees marking quality  
 Printhead with embedded intelligence for high marking quality and reduced maintenance  
 Broad range of dye and pigment inks: multi-use, high performance; alcohol based, ketone-free and MEK-free inks  
 Sealed 0.6 and 08-liter consumable cartridges with fool proofing system  
 Compact and modular ink circuit for better thermal management and controlled additive consumption  
 100% front access modular ink circuit for a simplified preventive maintenance  
 Quick connect/disconnect of accessories (photocell, alarm and encoder)  
 Enhanced native connectivity including USB, Ethernet, serial and a configurable M12 connector for I/O

## Remote services

Our intelligent self-support solution. Live helpdesk support with remote video capabilities  
 Markem-Imaje Connected Printer Services powered by a secure IoT platform\*\*

## Options

Ultra-flexible 6-meter umbilical cable  
 Consumable saving mode for up to -60% additive consumption: at 20 °C less than 3,5 cc/h for MEK-based ink or less than 2cc/h for MEK-free ink  
 Printhead pressurization kit  
 Air blade kit  
 Many I/O possibilities including a configurable single point connector (24 pins)

## Accessories

Wide range of accessories  
 Printer supports: stands (stainless steel or aluminum), table or wall mounting brackets  
 Printhead supports: stand (stainless steel) and choice of brackets  
 Pigment ink shaker  
 Photocells  
 Encoders  
 Alarm beacons (24 V)  
 Set of pre-cabled connectors M12, Ethernet IP66

## Software

Fully compatible with CoLOS® Version 6.3 Service Pack onwards  
 Logo creation with CoLOS® Version 6.4 Graphics software

\*TCO: Total cost of ownership. VOC: Volatile organic compounds. OEE: Overall equipment effectiveness. \*\*Internet of things, please check availability in your country



markem·imaje  
 a DOVER company

9, rue Gaspard Monge - B.P. 110  
 26501 Bourg-lès-Valence Cedex France  
 +33 (0) 4 75 75 55 00  
 markem-imaje.com