

NASTRO-SB™ -M5-M6-M8

The Next Benchmark



SEMI-AUTOMATIC CASE SEALER

100%
MADE in ITALY

NASTRO-SB™ - M5 - M6 - M8

Nastro-SB™ - M is a range of semi-automatic heavy duty case sealing machines engineered by SIAT specifically for small, medium, large and king fixed box sizes. Nastro-SB™ is the ideal case sealing machine for a variety of industries like food & beverage, chemical, clothes and wine.

SPECIFICATIONS

Max Production Capacity: 1200 boxes/hour

Case type: RSC - FEFCO 0201

Max case weight: 32 kg

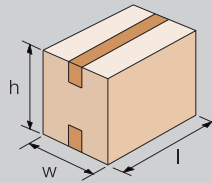

Box dimensions	L (mm)	W (mm)	H (mm)
M5-S	150 - ∞	150 - 500	120 - 500
M5-L	150 - ∞	105 - 500	50 - 500
M6-S	150 - ∞	150 - 650	120 - 650
M6-L	150 - ∞	105 - 650	50 - 650
M8	150 - ∞	150 - 800	120 - 800

KEY FEATURES

- » Lockable power switch
- » Central (M5) or double side (M6-M8) emergency button
- » Removable heads without tools
- » 75 mm high belt conveyor
- » Easy to replace belt without removing the conveyor
- » 50 mm minimum box height (with L version)
- » Heavy duty column assembly
- » Heavy duty belt conveyor assembly
- » Lockable on/off motors switch
- » Top and bottom taping head removable without tools

ENERGY SAVING VERSION

Motors and conveyors stop after a defined time when no cartons are detected

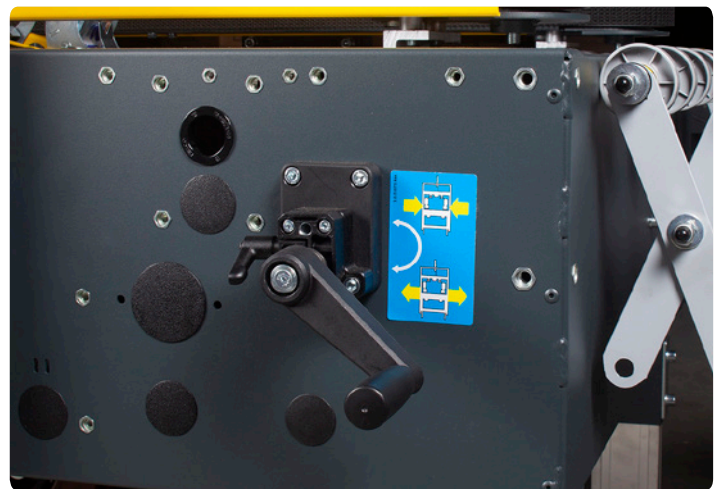

Top taping unit position adjustment handle

Central emergency button

Bottom taping unit

Top taping unit

Easy to maintain belt conveyor

On/off lockable switch

Belt conveyor position adjustment handle

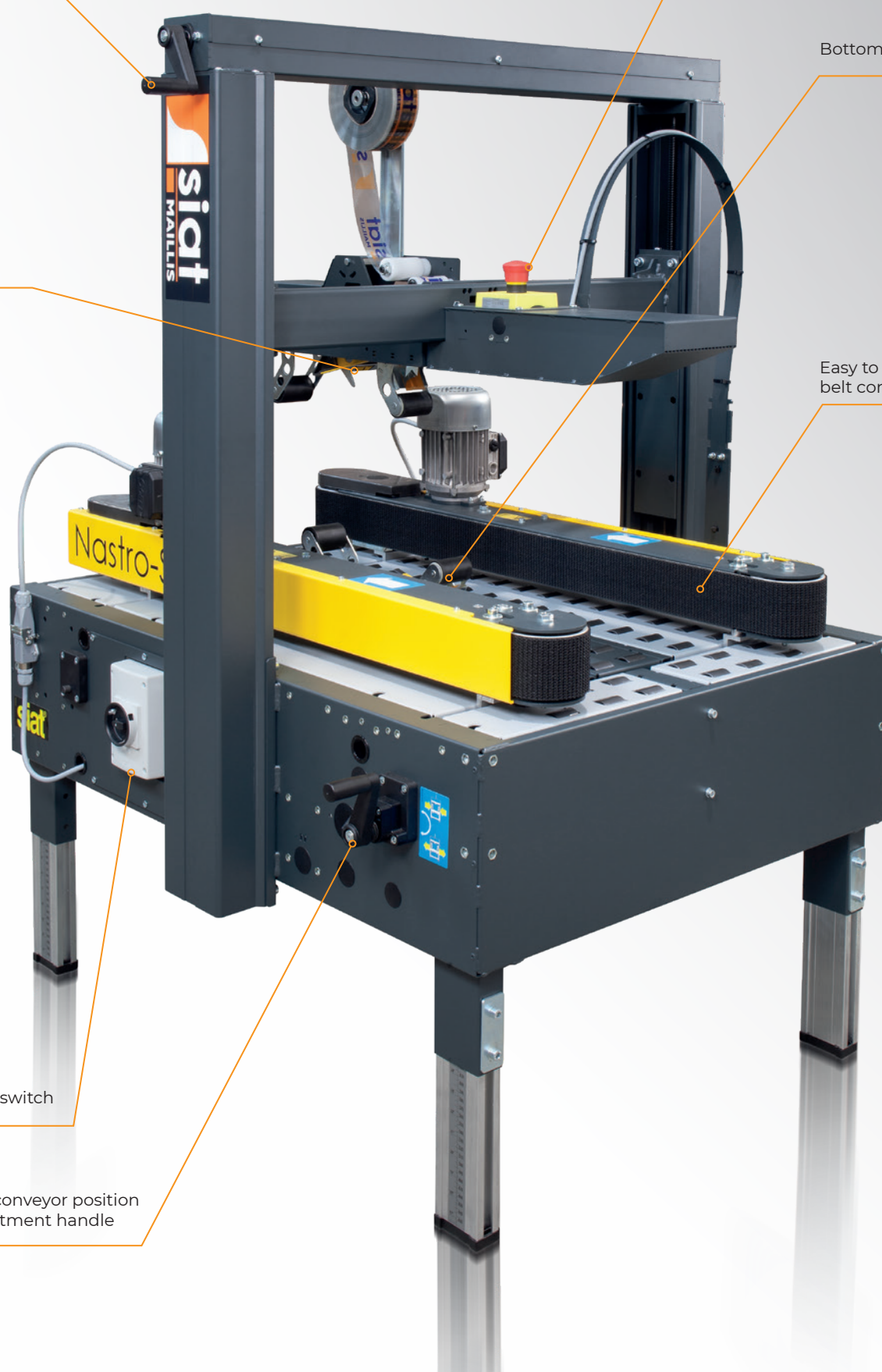

NASTRO-SB™ - M5 - M6 - M8

Machine dimensions

Dimensioni macchina
Maschinenabmessungen
Dimensions machine
Dimensiones de máquina

	Model	Min (mm)	Max (mm)
Total H	M5-S/M5-L	1315	1575
	M6-S/M6-L	1460	1720
	M8	1575	1835
H Bench	ALL	540	800
W	M5-S/M5-L	1085	1085
	M6-S/M6-L	1240	1240
	M8	1390	1390
L	ALL	1100	1100

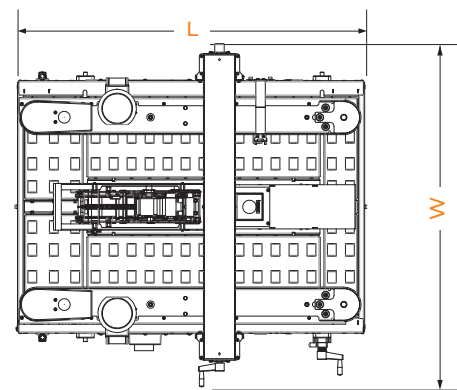
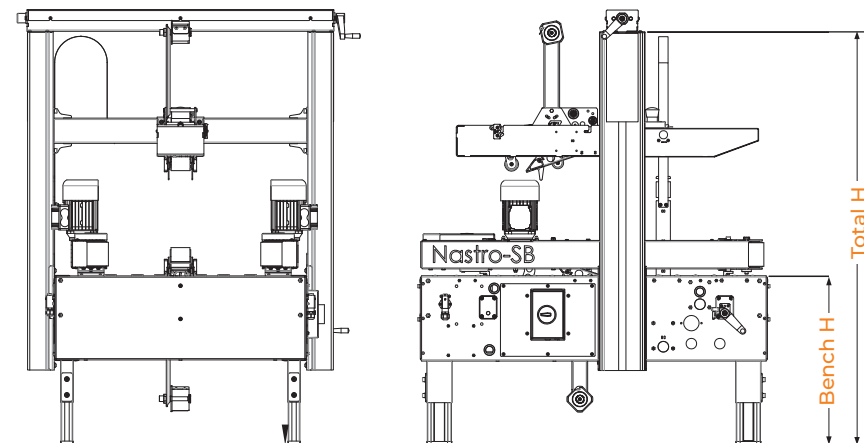

Max Production capacity

Capacità di produzione
Produktionskapazität
Capacité de production
Capacidad de producción

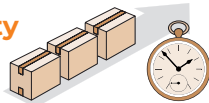

up to 1200 Bph

Standard power supply

Alimentazione standard
Standard-Stromanschluß
Alimentation électrique standard
Fuente de alimentación estándar

380/415V_50HZ_3PH+N+PE	
220/240V_50HZ_1PH+N+PE	
Amps	1,08
Power kW	0,26

Optional Extras

Accessori
Zubehör
Accessories
Accesorios

GTL - GTR

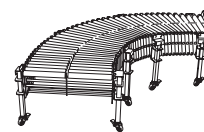

Higher Legs



Nastro legs low height (440-700 mm)
Nastro legs max height (760-1020 mm)

AS77

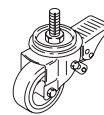

RG

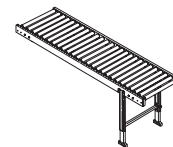

SIAT Spa

Via Puecher 22, 22078 Turate - Como
www.siat.com

100%
MADE in ITALY

SIAT S.p.A is recognised worldwide as a top-class machine manufacturer for secondary packaging and produces more than 17,000 machines per year, and has done since 1970. Our product range includes semi-automatic as well as fully automatic machines like Case Sealers and Case Erectors, Stretch Wrappers, Strapping Tools / Machines, Flexographic Printing Machines and Tape Dispensers. The company is present in more than 100 countries and is constantly investing worldwide to meet customers actual and future demands.